

THIS DOCUMENT CONTAINS DATA PROPRIETARY TO PROJECTS UNLIMITED, INC. ANY USE OR REPRODUCTION, IN ANY FORM, WITHOUT PRIOR WRITTEN PERMISSION OF PROJECTS UNLIMITED, INC. IS PROHIBITED.
 © 2005, Projects Unlimited Inc.

SPECIFICATIONS

PARAMETERS	VALUES	UNITS
RATED VOLTAGE	6	Vdc
OPERATING VOLTAGE RANGE	4 ~ 9	Vdc
RATED CURRENT (MAX)	35	mA
MINIMUM SPL @ 10 CM	100	dBA
RESONANT FREQUENCY	2800±200	Hz
TONE OR PULSE RATE	CONTINUOUS	0 PULSE PER SECOND
OPERATING TEMPERATURE	-20 ~ +60	°C
STORAGE TEMPERATURE	-30 ~ +70	°C
HOUSING MATERIAL	ABS	-
TERMINAL MATERIAL	Sn PLATED COPPER	-
WEIGHT	9	grams

REVISIONS			
LTR	DESCRIPTION	DATE	APPROVED
-	RELEASED FROM ENGINEERING	8/9/06	

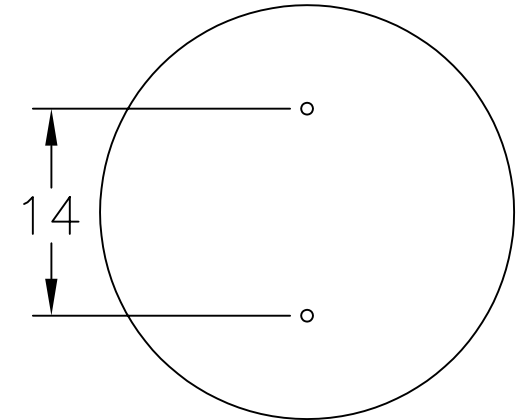
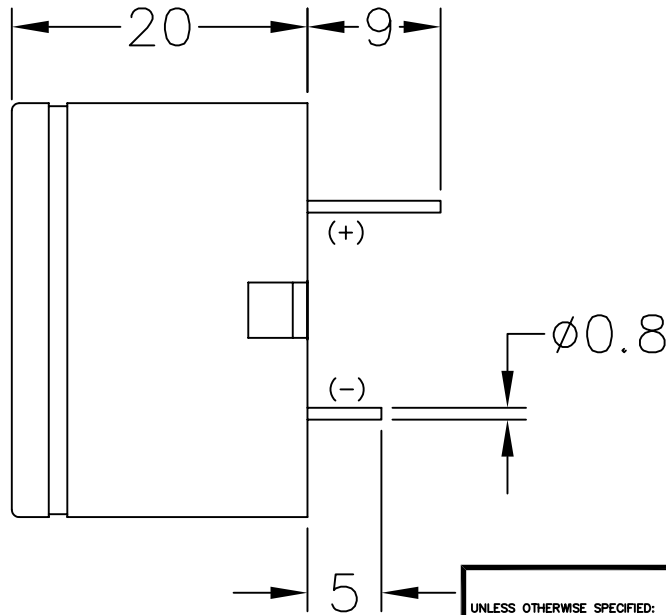
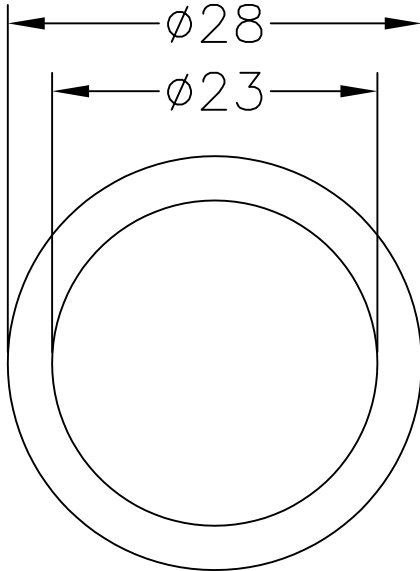

NOTES:

1. ALL DIMENSIONS ARE IN MILLIMETERS.
2. SPECIFICATION SUBJECT TO CHANGE OR WITHDRAWAL WITHOUT NOTICE.
3. THIS PART IS RoHS 2002/95/EC COMPLIANT.

FILE NAME
 AI-2828-TT-6V-R.DWG

UNLESS OTHERWISE SPECIFIED:
 DIMENSIONS ARE IN MILLIMETERS, TOLERANCES ARE ±0.5 AND ANGLES ARE ±3°.

APPROVALS	DATE
DRAWN <i>J.D.</i>	8/06
CHECKED <i>R.W.</i>	8/06
APPROVED <i>B.R.</i>	8/06

 projects [®] unlimited Dayton, Ohio	
<h1>INDICATOR</h1>	
DRAWING NO. AI-2828-TT-6V-R	SIZE A
SCALE: N.T.S. SHEET 1 OF 1	

DO NOT SCALE DRAWING